

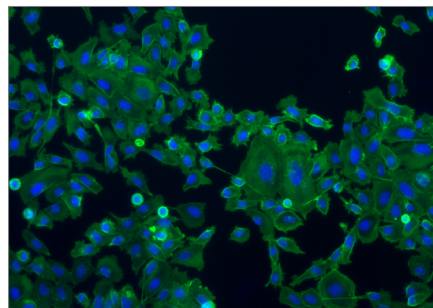

ZEISS Axio Vert.A1

Your Inverted Microscope for Advanced Laboratory Applications



HeLa cells - 2 channel fluorescence

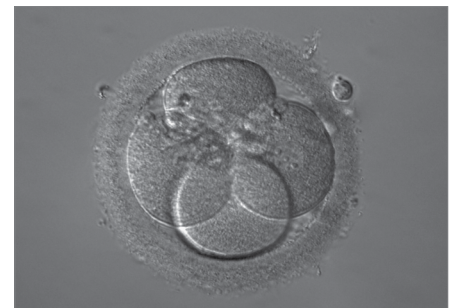

Embryo: nucleus with nucleoli visible in right cell - iHMC

Choose from all standard contrasting techniques, including DIC, to investigate your cell cultures. Axio Vert.A1 provides brilliant images in answer to your research questions.

Axio Vert.A1 is the only system in its class with such a large range of features, yet is compact enough to sit directly beside your incubator. Gain insights into the smallest details of your research while keeping your cell culture in its own protected environment.

Highlights

- All standard contrast techniques plus improved Hoffman Modulation Contrast (iHMC), fluorescence contrast and Differential Interference Contrast (DIC)
- LED excitation with no unwanted UV is gentle on your living samples. Profit from an extremely long life time of the light source. Works immediately with full intensity - no heating or cooling period required.
- Specific IVF contrast system for IVF labs
- Ergonomic design allows you to sit or stand while you work. Use the intermediate pieces and ergo tube to view samples more easily and comfortably.

Contrast Methods for Every Detail

Axio Vert.A1 features a full range of contrast techniques: brightfield, phase contrast, PlasDIC, improved Hoffman Modulation Contrast (iHMC), fluorescence contrast and Differential Interference Contrast (DIC). With DIC you visualize even the finest structures in your cells.

The Special Contrast System for IVF Labs

Without modifying the stand, switch freely between iHMC, PlasDIC and DIC as you investigate your samples. Adapt all standard micromanipulators to the stable transmitted light arm of your Axio Vert.A1 for vibration free working.





ZEISS Axio Vert.A1

Your Inverted Microscope for Advanced Laboratory Applications

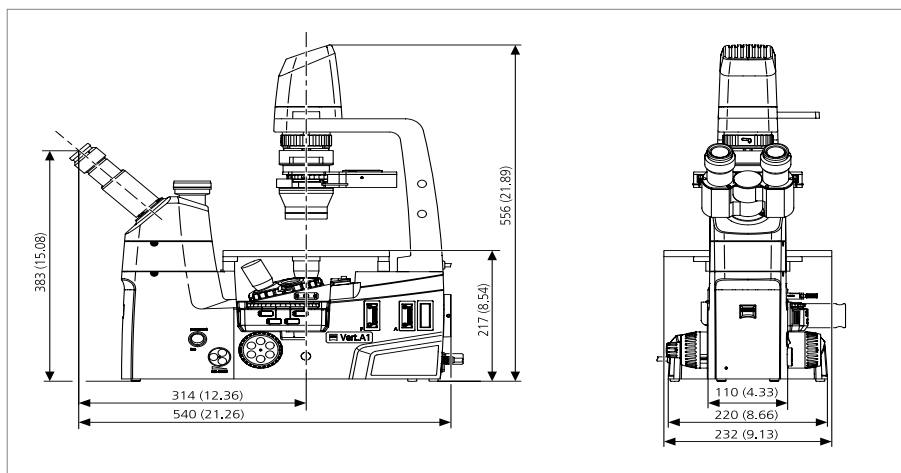

Special Features:

- Huge range of contrast techniques in one microscope
- All optical components in Axio Vert.A1 are anti-fungus treated.

Suitable Applications:

- IVF
- Reproductive Biology
- Cancer research
- Immunology
- Microbiology
- Cell culture
- Live cell Imaging
- Neurobiology
- Vascular biology
- Transgenetics
- Plant biology

Accessories Available:

- Aquestop
- A variety of stages
- Micromanipulation
- Mounting frames and incubators
- Various binocular phototubes
- Various ergo intermediate pieces
- Cameras
- ZEN software

Technical Data			
Stand	Axio Vert.A1 - manual inverted stand, transmitted light Axio Vert.A1 FL - manual inverted stand, transmitted light and fluorescence Axio Vert.A1 FL-LED - manual inverted stand, transmitted light and LED fluorescence		
Dimensions (W x D x H)	235 x 560 x 560 mm, including required space for cabling and plugs		
Weight	Axio Vert.A1: 10.5 kg	Axio Vert.A1 FL: 11.7 kg	Axio Vert.A1 FL-LED: 12.3 kg
Eyepieces	Field number 23 (W-PI 10x/23 br foc), diameter: 30 mm		
Objectives	Nosepiece turret (included with stand): 5x, H DIC M27 man. (2x H, 3x H DIC) 1.25x-100x, A-Plan, LD A-Plan, LD Plan-NEOFLUAR (optional)		
Illumination (transmitted light)	Hal 100 (Halogen) LED	Output: 37 W, controllability: continuous, ≤ 1,5 to 12V Output: 3 W, controllability: continuous, ≤ 1,5 to 12V	
Contrast methods	Included in all stands: Optional:	Brightfield Phase contrast, PlasDIC, iHMC, DIC	
Condensors	(all optional) LD-condensor 0,3 for slider, LD-condensor 0,4 for slider, LD-condensor 0,4 for H Ph PlasDIC DIC iHMC, LD-condensor 0,55 for H Ph PlasDIC DIC		
Fluorescence:	Axio Vert.A1	Axio Vert.A1 FL	Axio Vert.A1 FL-LED
HBO 50	-	optional	-
HBO 100	-	optional	-
HPX 120 C	-	optional	-
4-position mount for LED modules	-	-	included
4-position reflector turret	-	included	included



microscopy@zeiss.com
www.zeiss.com/axiovert



Instruments
info@ctk-instruments.com
www.ctk-instruments.com
866-464-1005

